

THIS DRAWING IS UNPUBLISHED. RELEASED FOR PUBLICATION
 © COPYRIGHT BY TYCO ELECTRONICS CORPORATION. ALL RIGHTS RESERVED.

LOC	DIST	REVISIONS					
AD	00	P	LTR	DESCRIPTION	DATE	DWN	APVD
		R		EC 0G3C 0212 05	05APR05	BSV	DLS

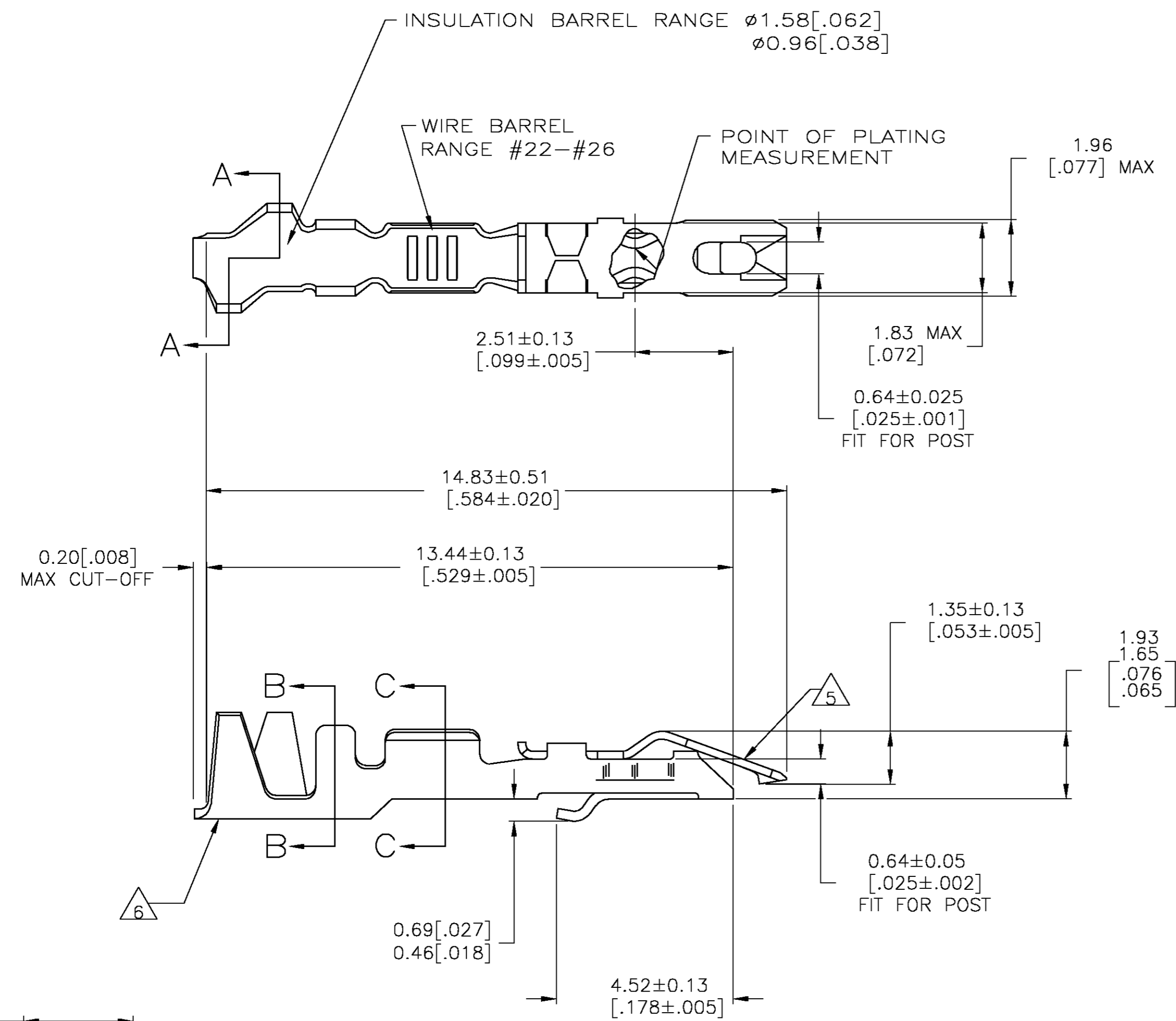

- 1 PLATED WITH 0.00076[.000030] GOLD IN CONTACT AREA, GOLD FLASH ON REMAINDER, OVER 0.00127[.000050] NICKEL.
- 2 PLATED WITH 0.00127[.000050] GOLD IN CONTACT AREA, GOLD FLASH ON REMAINDER, OVER 0.00127[.000050] NICKEL.
- 3 PLATED WITH 0.00254[.000100] BRIGHT TIN-LEAD OVER 0.00127[.000050] NICKEL - ENTIRE CONTACT.
- 4 PLATED WITH 0.00127[.000050] GOLD OVER 0.00127[.000050] NICKEL - ENTIRE CONTACT.
- 5 SPRING MATERIAL: STAINLESS STEEL
- 6 BODY MATERIAL: PHOS BRONZE FINISH: SEE TABLE
- 7 PLATED WITH 0.00254[.000100] BRIGHT TIN OVER 0.00127[.000050] NICKEL - ENTIRE CONTACT.

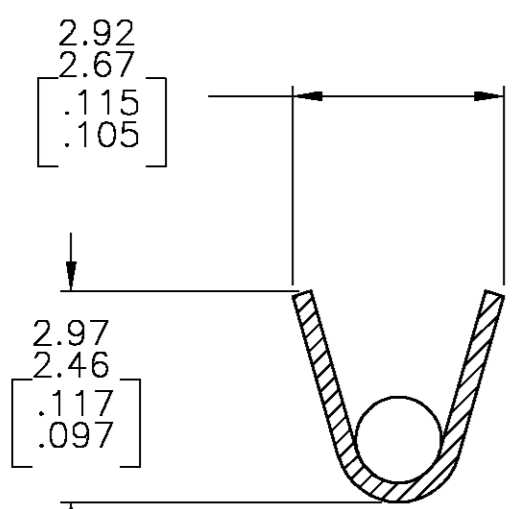

A-A
(ROTATED 90° CLOCKWISE)

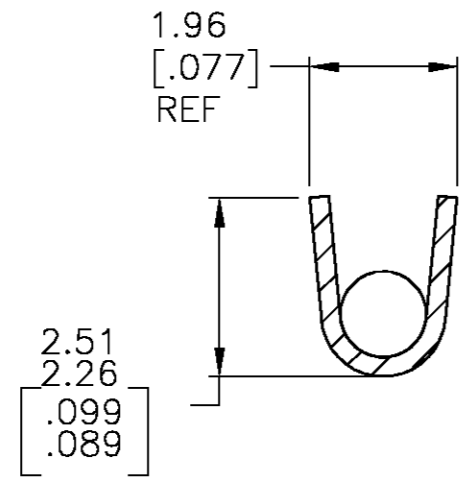

B-B

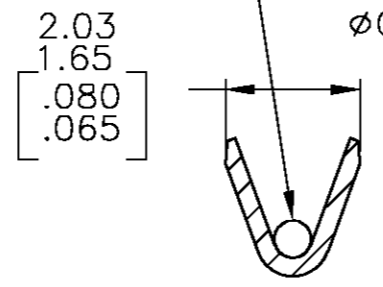

C-C

OBSOLETE	7	87124-2	5-87165-2
	4	87124-4	87165-4
	2	87124-3	87165-3
	3	87124-2	87165-2
	1	87124-1	87165-1
BODY FINISH		STRIP PART NUMBER	PART NUMBER

THIS DRAWING IS A CONTROLLED DOCUMENT.

DIMENSIONS: mm [INCHES]	TOLERANCES UNLESS OTHERWISE SPECIFIED:	DWN E. BRANDBERG 23NOV94	Tyco Electronics Corporation Harrisburg, Pa 17105-3608	
	0 PLC ± -	CHK S. SHUEY 23NOV94	NAME	CONTACT - LOCKING CLIP, FOR 0.64[.025] SQUARE POST, LOOSE PIECE
	1 PLC ± -	APVD D. DUPLER 23NOV94	PRODUCT SPEC	
	2 PLC ± -		APPLICATION SPEC	
	3 PLC ± -			
MATERIAL AS NOTED	FINISH SEE TABLE	4 PLC ± -	SIZE A2	CAGE CODE 00779
		ANGLES ± -	DRAWING NO C=87165	RESTRICTED TO
		FINISH ± -	SCALE 10:1	SHEET 1 OF 1
			CUSTOMER DRAWING	REV R